



**G. S. I. Inc.**

*Manufacturer & Distributor of Aerospace Lighting*

E-Mail: [gsiinc@knology.net](mailto:gsiinc@knology.net)

**Godfrey Systems International, Inc.**

3051 Pine Street ☐ Clearwater, FL. 33763-0914 ☐ U. S. A.

Tel: (727) 799-4916 ☐ Fax: (727) 724-0212

[HOME](#)

[PRODUCTS](#)

[WHAT'S NEW](#)

[WHO WE ARE](#)

[BUSINESS PARTNERS](#)

## H.I.D. AIRCRAFT LIGHTING & BOOM BAR

*You May Never Have To Change Another Lamp!*

### Applications:

LoPresti Speed Merchants are proud in making the brightest idea in aircraft lighting possible; the High Intensity Discharge (H.I.D.) Xenon Landing Light System.

Along with this system, LoPresti Speed Merchants have also created the new H.I.D. Boom Bar for the helicopter industry.

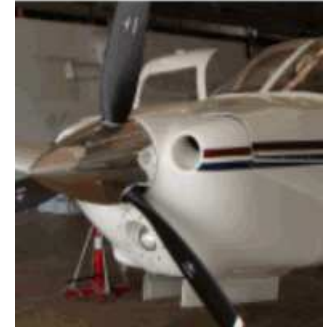

### HID Aircraft Lighting:

This exciting new technology uses mercury and xenon gases to create and maintain the light source. The gases are ignited by applying power to 2 electrodes within a glass tube, thus creating a light that yields more true colors. This gives a much better night view.

Normal incandescent lamps are fragile, where any vibration or shock can cause them to fail. Through the H.I.D.'s extensive testing, even the rough environment of flight training doesn't surpass its merit.

H.I.D. Lighting Systems include power supply, shielded high voltage wire harness, plug in H.I.D. lamp, mounting hardware, and your choice of lens reflector assembly.



### H.I.D. Boom Bar:

Currently in use on many aircraft, the H.I.D. Boom Bar is an extremely cost effective, high brightness lighting system. The H.I.D. Boom Bar consists of 9 highly reliable, low power consumption lights. Therefore, the Boom Bar will light up the night without draining power from the helicopter.

Boom Bars come in 14 V or 28 V to match most airframes. Sturdy brackets mount this lighting system, which makes it easy to mount and gives a variety of options for different positions. Cabling to match your aircraft interface is also included.



As with regular H.I.D. Lighting Systems, mercury and xenon gases create and maintain the light source. With shock and vibration, regular incandescent lamps do not match the Boom Bar's high quality. With no filaments to burn out, the Boom Bar is most reliable. The H.I.D. Lamp is so rugged that we warrant the light for 5 years.



### Advantages:

- 5 year warranty on all parts, including lamp burnout.
- Up to 5 times the candlepower of standard light.
- PAR 46 / 5.75 in (14.60 cm) reflector, PAR 36 / 4.5 in (11.43 cm) reflector, PAR 56.
- Can be left on continuously, having a 5,000 hour lamp life.
- Reduces load on alternator, system uses less than 3 Amps.

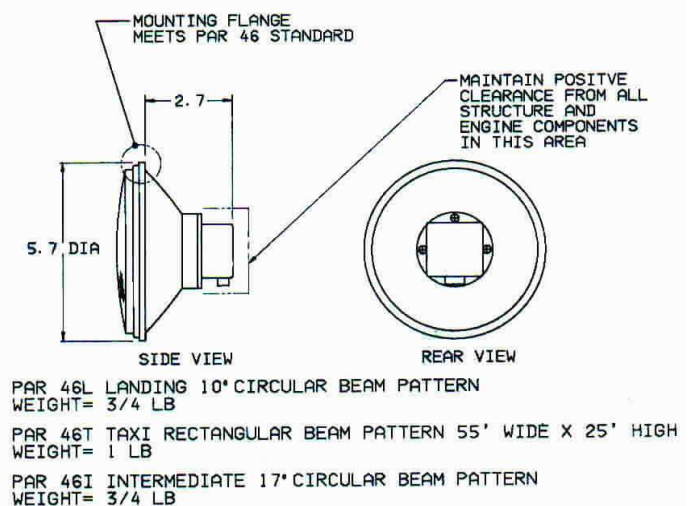

☐ H.I.D. Lamps, due to their design and construction,  
do not produce excessive heat that standard incandescent lamps do.

☐ Available in 3 widths: Taxi - 54 ° width, Intermediate - 17 ° width, Landing - 9 ° width.

**Sold & Serviced in the United States & Canada by G. S. I. Inc.**

Manufactured by:



LoPresti Speed Merchants

2620 Airport North Drive ☐ Vero Beach, FL. 32960 ☐ U. S. A.

Tel: (772) 562-4757 ☐ Fax: (772) 563-0446

E-mail: [info@speedmods.com](mailto:info@speedmods.com) ☐ Website: [www.speedmods.com](http://www.speedmods.com)

[HOME](#)

[PRODUCTS](#)

[WHAT'S NEW](#)

[WHO WE ARE](#)

[BUSINESS PARTNERS](#)

Created By KMPH - Web Architect, G. S. I. Inc.

Updated: *May 18, 2006*

©1997-2006 ☐ All Rights Reserved

Wade   
Publishing